

Φ10.5mm 650nm Laser Module

Power set by user

Features

1. APC (auto power control) IC inside
2. Low current consumption of the APC circuit
3. Surge current protection
4. High quality glass lens for output beam
5. Adjustable focus

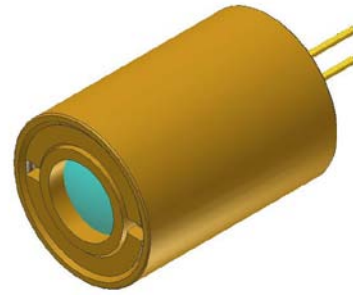

Absolute maximum ratings

Item	Symbol	Rating	Unit
Power supply voltage	V _{cc}	3.3	V
Laser Module optical output power	P _o	<3	mW
Operation temperature	T _{opr}	-5~50	°C
Storage temperature	T _{stg}	-20~70	°C

Electrical and optical characteristics (T_c=25 °C)

Item	Symbol	Min.	Typ.	Max	Unit	Condition
Wavelength	λ	-	655	-	nm	P _o = 3mW
Operation current	I _{op}	-	-	35	mA	P _o = 3mW V _{cc} =3V
Operation voltage	V _{op}	2.5	-	3.3	Volt	
Laser Beam spot size at 10m		<8mm				
Divergence angle		0.9 mrad				
Mean time to failure (MTTF) 25°C		>10000 hrs				

Outline dimensions (Units: mm)

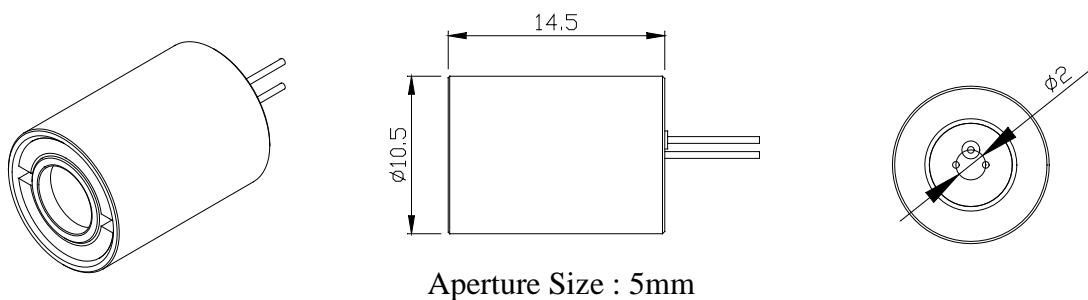

Laser Safety Precautions

1. Do not look into the laser beam directly by eyes. The laser beam may cause severe damage to human eyes.
2. Optical Lens is made of plastic or glass. Do not contaminate lens by soiling, oil or chemical.

** For reference only. Contents above are subject to change without notice.*

Contact

For US, Canada Ayase America Inc.
 For EU Ayase Europe GmbH
 For Japan Ayase Co., Ltd.

e-mail: info@ayaseamerica.com
 e-mail: info@ayase-europe.de
 e-mail: info@ayasecorporation.com

+1-408-988-5277
 +49-0-6122-533-811
 +81-45-532-9501

PIN Assignment:

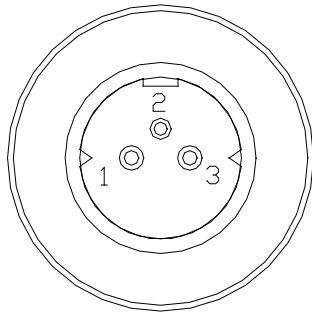

A type : Heat sink stand (-)

Pin 1 : Vcc
Pin 2 : GND
Pin 3 : PD

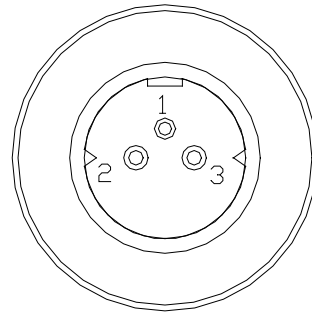

B type :Heat sink stand (+)

Laser power Adjustment Procedure

1. Connect 1 uF capacitor (Cx1) between Pin1 and Pin2.
2. Connect 20~50K ohm variable resistor (Rx1) between Pin2 and Pin3.
3. Set Vcc to the designed value.
4. Adjust Rx1 to obtain the desired output power.
5. Laser Safety Precautions

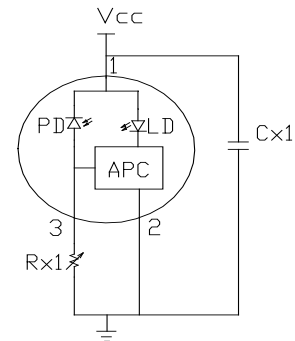

- (1) Do not increase Vcc value when the laser module is working near the maximum power . That is to protect laser from overdriving condition and make sure power is under 3 mW.
- (2) Do not operate the device above the maximum rating condition, even momentarily. It may cause unexpected permanent damage to the device.

Laser power stability

P1 : 2.5mW
P2 : < 3mW
Pn : <3mW
 ΔP : < 0.5mW
T1 : < 0.1us
 $f2=(1/T2)$: 3MHz

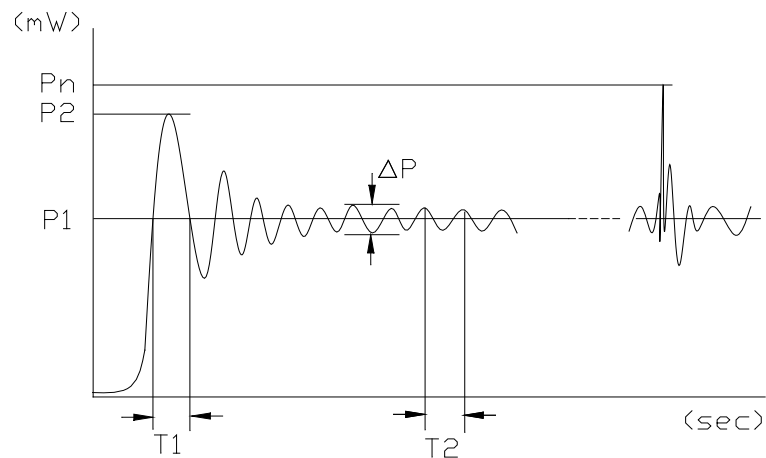

NOTE:

P1 : Mean power
P2 : Max power from turning on power
Pn : Max power from Vcc noise
 ΔP : Power Amplitude of vibration
T1 : Time between trigger and convergence
 $f2=(1/T2)$: Frequency of output power

** For reference only. Contents above are subject to change without notice.*

Contact

For US, Canada
For EU
For Japan

Ayase America Inc.
Ayase Europe GmbH
Ayase Co., Ltd.

e-mail: info@ayaseamerica.com
e-mail: info@ayase-europe.de
e-mail: info@ayasecorporation.com

+1-408-988-5277
+49-0-6122-533-811
+81-45-532-9501