

Φ10.5mm 650nm Laser Module

Power set by user

Features

1. APC (auto power control) IC inside
2. Low current consumption of the APC circuit
3. Surge current protection
4. High quality glass lens for output beam
5. Fixed focus



Absolute maximum ratings

Item	Symbol	Rating	Unit
Power supply voltage	V _{cc}	3.3	V
Laser Module optical output power	P _o	<3	mW
Operation temperature	T _{opr}	-5~50	°C
Storage temperature	T _{stg}	-20~70	°C

Electrical and optical characteristics (T_c=25 °C)

Item	Symbol	Min.	Typ.	Max	Unit	Condition
Wavelength	λ	-	655	-	nm	P _o = 3mW
Operation current	I _{op}	-	-	35	mA	P _o = 3mW V _{cc} =3V
Operation voltage	V _{op}	2.5	-	3.3	Volt	
Laser Beam spot size at 10m		<8mm				
Divergence angle		0.9 mrad				
Mean time to failure (MTTF) 25°C		>10000 hrs				

Outline dimensions (Units: mm)

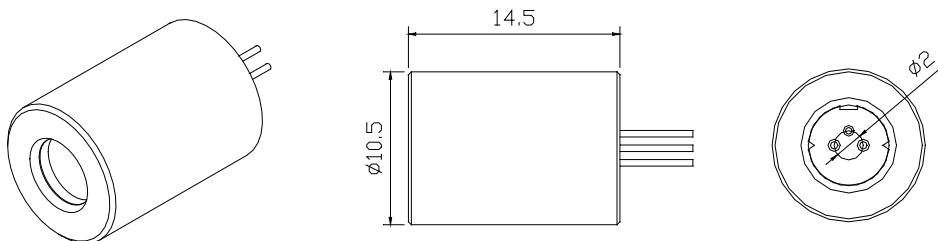

Aperture Size : 5mm

Laser Safety Precautions

1. Do not look into the laser beam directly by eyes. The laser beam may cause severe damage to human eyes.
2. Optical Lens is made of plastic or glass. Do not contaminate lens by soiling, oil or chemical.

Contact

For US, Canada
For EU
For Japan

Ayase America Inc.
Ayase Europe GmbH
Ayase Co., Ltd.

e-mail: info@ayaseamerica.com
e-mail: info@ayase-europe.de
e-mail: info@ayasecorporation.com

+1-408-988-5277
+49-0-6122-533-811
+81-45-532-9501

PIN Assignment:

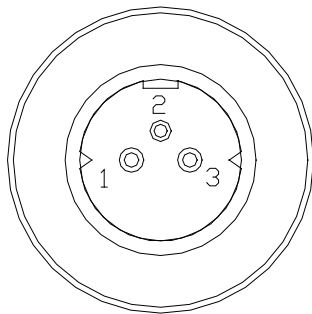

A type : Heat sink stand (-)

- Pin 1** : Vcc
- Pin 2** : GND
- Pin 3** : PD

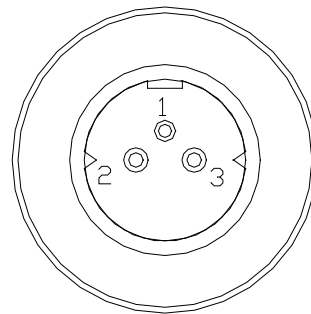

B type :Heat sink stand (+)

Laser power Adjustment Procedure

1. Connect 1 uF capacitor (Cx1) between Pin1 and Pin2.
2. Connect 20~50K ohm variable resistor (Rx1) between Pin2 and Pin3.
3. Set Vcc to the designed value.
4. Adjust Rx1 to obtain the desired output power.
5. Laser Safety Precautions

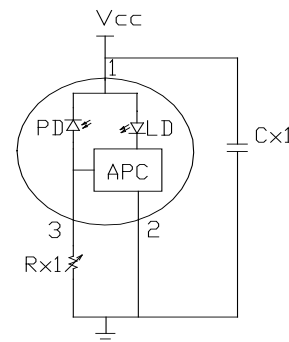

- (1) Do not increase Vcc value when the laser module is working near the maximum power . That is to protect laser from overdriving condition and make sure power is under 3 mW.
- (2) Do not operate the device above the maximum rating condition, even momentarily. It may cause unexpected permanent damage to the device.

Laser power stability

- P1 : 2.5mW
- P2 : < 3mW
- Pn : <3mW
- ΔP : < 0.5mW
- T1 : < 0.1us
- $f2=(1/T2)$: 3MHz

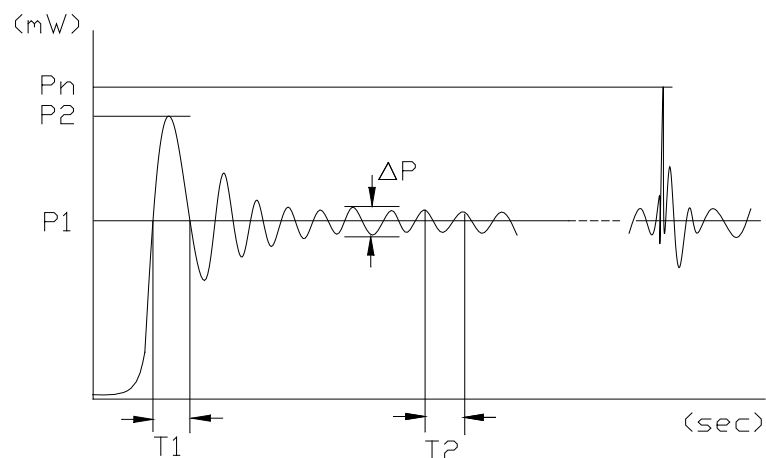

NOTE:

- P1 : Mean power
- P2 : Max power from turning on power
- Pn : Max power from Vcc noise
- ΔP : Power Amplitude of vibration
- T1 : Time between trigger and convergence
- $f2=(1/T2)$: Frequency of output power