

AlGaAs Infrared Laser Diode

ADL-78901SX
6-2D-LD78-006_Rev.01

★780nm, 90mW Reliable Operation

200mW High Power Pulse Reliable Operation

φ3.3mm Mini Package!

• Features

1. Smallest package
2. Small aspect ratio
3. High COD level

• Applications

1. Virtual keyboard
2. Super slim 40X CD-R/RW OPU

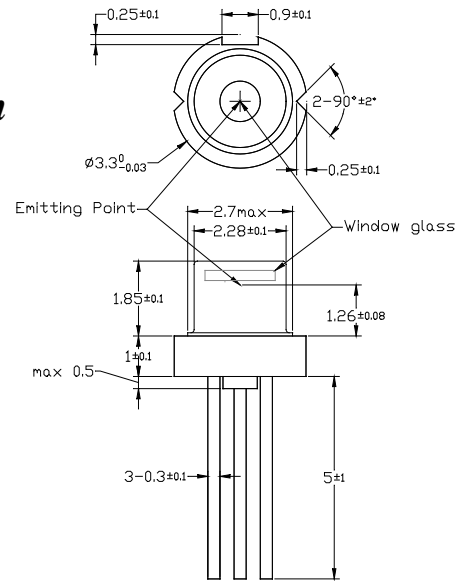

• Absolute maximum ratings

Parameter	Symbol	Condition	Rating	Unit
Light output power	P _O	CW	100	mW
	P _{op}	Pulsed*	220	
Reverse voltage(LD)	V _{RL}	-	2	V
Case temperature	T _C	-	-10~+70	°C
Storage temperature	T _S	-	-40~+85	°C

* Pulse width 0.5us, duty cycle 50%

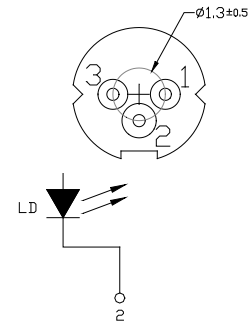

• Electrical and optical characteristics (T_C=25 °C)

Parameter	Symbol	Min.	Typ.	Max.	Unit	Conditions (CW)
Peak wavelength	λ	775	785	795	nm	P _o =90mW
Threshold current	I _{th}	25	35	55	mA	
Operating current	I _{op}	90	115	160	mA	
Operating voltage	V _{op}	1.5	2	2.2	V	P _o =80-90mW
Differential efficiency	η	0.8	1.1	1.3	mW/mA	
Parallel divergence angle	θ	7.5	9	10	deg	P _o =90mW
Perpendicular divergence angle	θ _⊥	15	17	19	deg	
Parallel FFP deviation angle	Δθ	-2	0	+2	deg	
Perpendicular FFP deviation angle	Δθ _⊥	-3	0	+3	deg	
Emission point accuracy	ΔxΔyΔz	-80	0	+80	um	

• Precautions

- * Do not operate the device above maximum ratings. Doing so may cause unexpected and permanent damage to the device.
- * Take precautions to avoid electrostatic discharge and/or momentary power spikes. A change in the characteristics of the laser or premature failure may result.
- * Proper heat sinking of the device assures stability and lifetime. Always ensure that maximum operating temperatures are not exceeded.
- * Observing visible or invisible laser beams with the human eye directly, or indirectly, can cause permanent damage. Use a camera to observe the laser.
- * No laser device should be used in any application or situation where life or property is at risk in event of device failure.

* For reference only. Contents above are subject to change without notice.

Contact

For US, Canada Ayase America Inc. e-mail: info@ayaseamerica.com +1-408-988-5277
 For EU Ayase Europe GmbH e-mail: info@ayase-europe.de +49-0-6122-533-811
 For Japan Ayase Co., Ltd. e-mail: info@ayasecorporation.com +81-45-532-9501

AlGaAs Infrared Laser Diode

ADL-78901SX

6-2D-LD78-006_Rev.01

* Specifications are subject to change without notice. Ensure that you have the latest specification by contacting us prior to purchase or use of the product

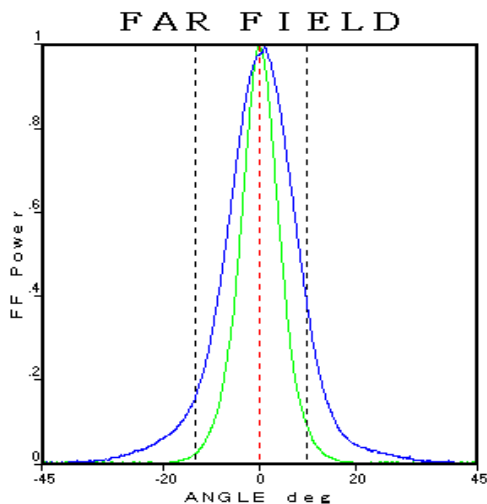
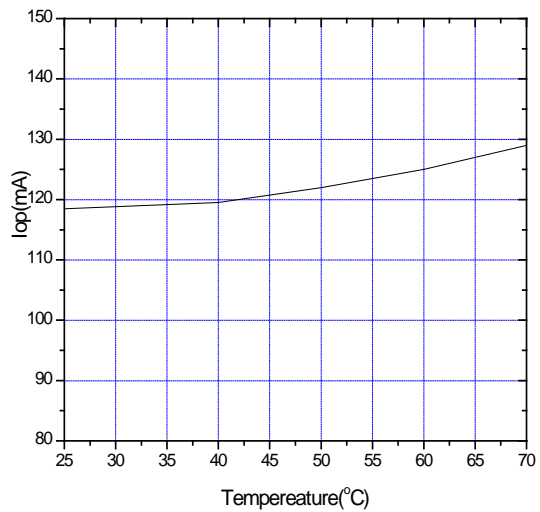
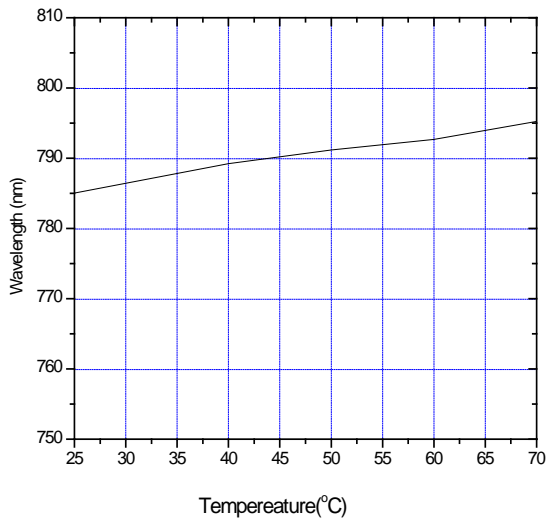
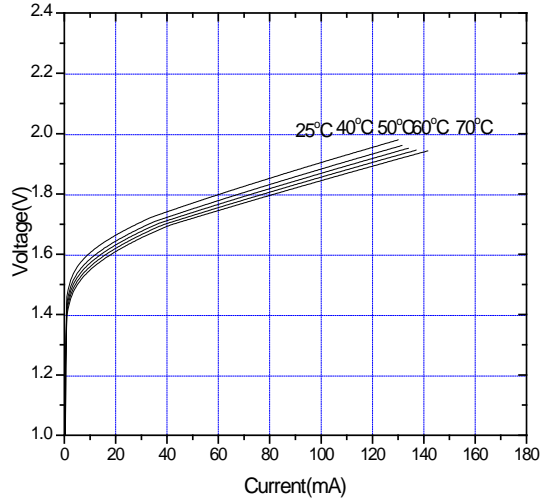
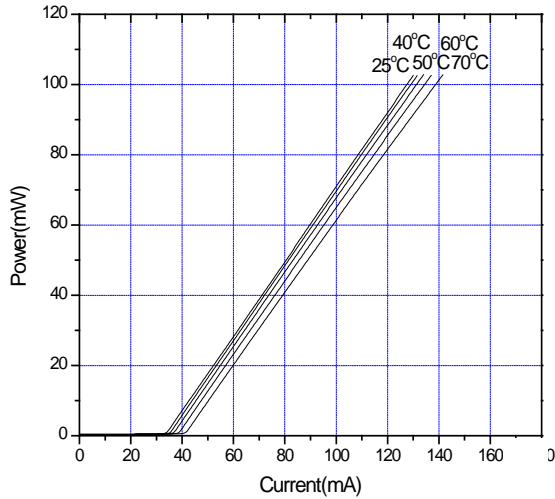

* For reference only. Contents above are subject to change without notice.

Contact

For US, Canada
For EU
For Japan

Ayase America Inc.
Ayase Europe GmbH
Ayase Co., Ltd.

e-mail: info@ayaseamerica.com
e-mail: info@ayase-europe.de
e-mail: info@ayasecorporation.com

+1-408-988-5277
+49-0-6122-533-811
+81-45-532-9501

