

# AlGaAs Infrared Laser Diode

ADL-78901TL

6-2D-LD78-004 Rev.01

★780nm, 90mW Power Reliable Operation

200mW High Power Pulse Reliable Operation

### Features

1. Small aspect ratio
2. High COD level

### Applications

1. Virtual keyboard
2. CD R/RW

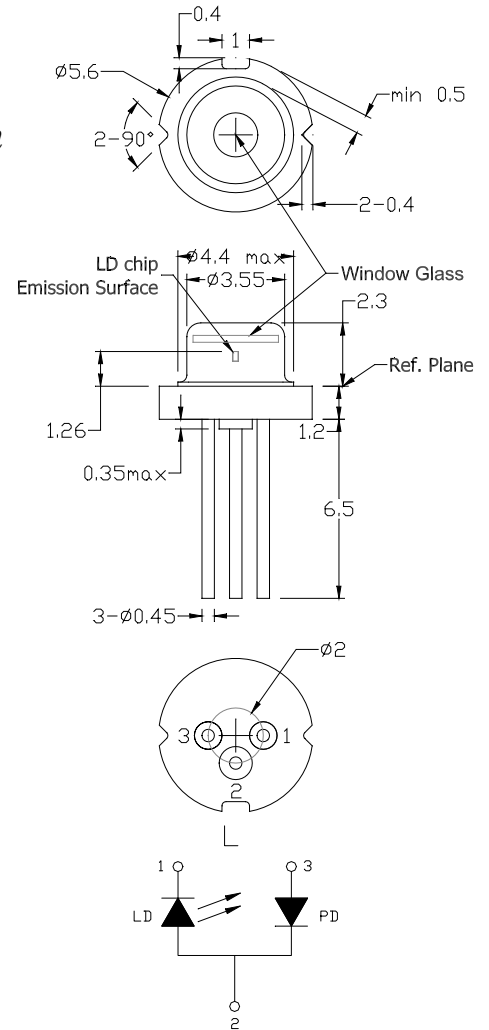

### Absolute maximum ratings

Parameter	Symbol	Condition	Rating	Unit
Light output power	$P_O$	CW	100	mW
	$P_{op}$	Pulsed*	220	
Reverse voltage(LD)	$V_{RL}$	-	2	V
Case temperature	$T_C$	-	-10~+70	°C
Storage temperature	$T_S$	-	-40~+85	°C

\* Pulse width 0.5us, duty cycle 50%

### Electrical and optical characteristics ( $T_c=25\text{ }^\circ\text{C}$ )

Parameter	Symbol	Min.	Typ.	Max.	Unit	Conditions (CW)
Peak wavelength	$\lambda$	775	785	795	nm	$P_o=90\text{mW}$
Threshold current	$I_{th}$	25	35	55	mA	$P_o:1\text{-}10\text{mW}$
Operating current	$I_{op}$	90	115	160	mA	$P_o=90\text{mW}$
Operating voltage	$V_{op}$	1.5	2	2.2	V	$P_o=90\text{mW}$
Monitor Current	$I_m$	0.1	0.3	0.7	mA	$P_o=90\text{mW}$ , $V_r=5\text{V}$
Differential efficiency	$\eta$	0.8	1.1	1.3	mW/mA	$P_o=80\text{-}90\text{mW}$
Parallel divergence angle	$\theta_{  }$	7.5	9	10	deg	$P_o=90\text{mW}$
Perpendicular divergence angle	$\theta_{\perp}$	15	17	19	deg	
Parallel FFP deviation angle	$\Delta\theta_{  }$	-2	0	+2	deg	
Perpendicular FFP deviation angle	$\Delta\theta_{\perp}$	-2	0	+2	deg	
Emission point accuracy	$\Delta x \Delta y \Delta z$	-80	0	+80	um	

### Precautions

- \* Do not operate the device above maximum ratings. Doing so may cause unexpected and permanent damage to the device.
- \* Take precautions to avoid electrostatic discharge and/or momentary power spikes. A change in the characteristics of the laser or premature failure may result.
- \* Proper heat sinking of the device assures stability and lifetime. Always ensure that maximum operating temperatures are not exceeded.
- \* Observing visible or invisible laser beams with the human eye directly, or indirectly, can cause permanent damage. Use a camera to observe the laser.
- \* No laser device should be used in any application or situation where life or property is at risk in event of device failure.
- \* Specifications are subject to change without notice. Ensure that you have the latest specification by contacting us prior to purchase or use of the product

\* For reference only. Contents above are subject to change without notice.

### Contact

For US, Canada Ayase America Inc. e-mail: [info@ayaseamerica.com](mailto:info@ayaseamerica.com) +1-408-988-5277  
 For EU Ayase Europe GmbH e-mail: [info@ayase-europe.de](mailto:info@ayase-europe.de) +49-0-6122-533-811  
 For Japan Ayase Co., Ltd. e-mail: [info@ayasecorporation.com](mailto:info@ayasecorporation.com) +81-45-532-9501

# AlGaAs Infrared Laser Diode

ADL-78901TL

6-2D-LD78-004 Rev.01

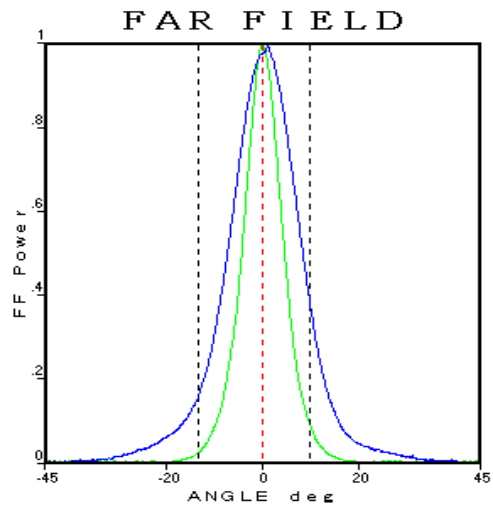
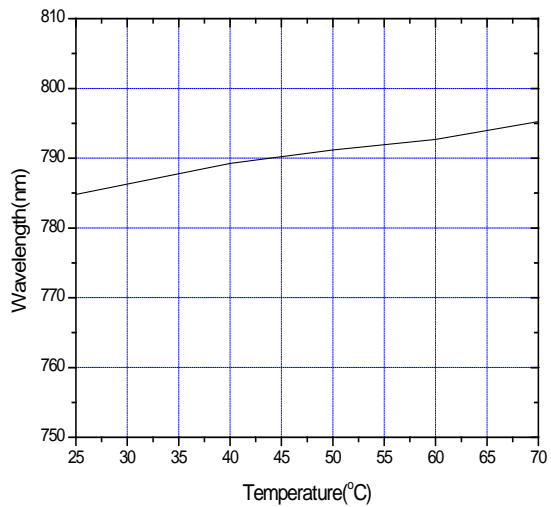
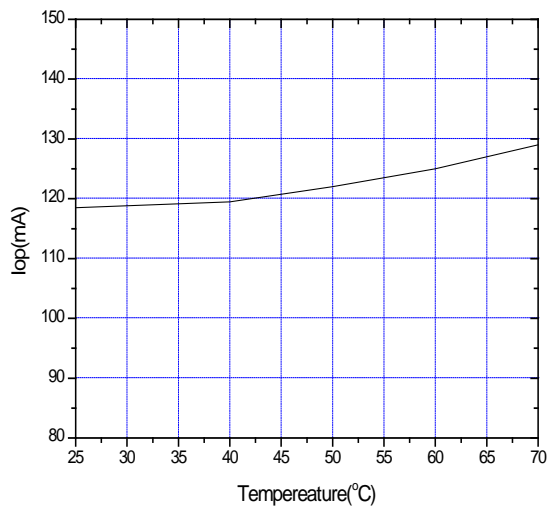
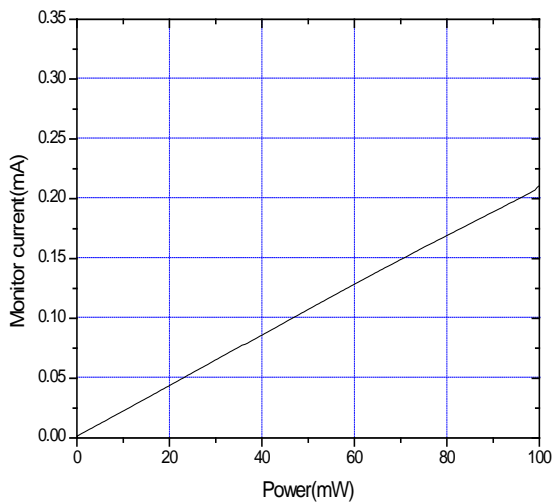
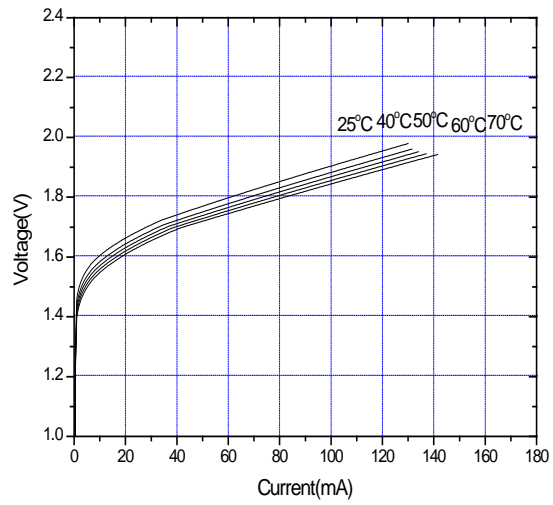
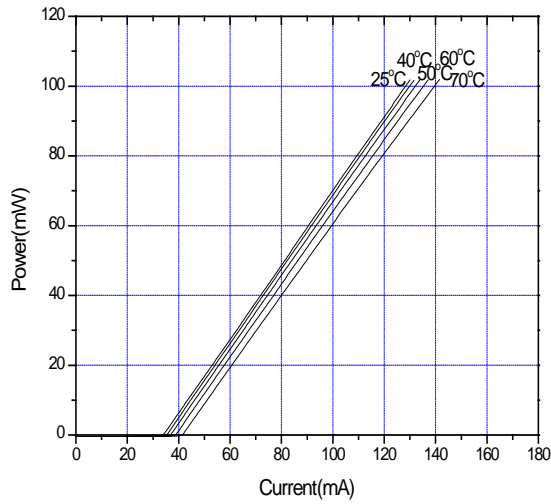

\* For reference only. Contents above are subject to change without notice.

Contact

For US, Canada  
For EU  
For Japan

Ayase America Inc.  
Ayase Europe GmbH  
Ayase Co., Ltd.

e-mail: [info@ayaseamerica.com](mailto:info@ayaseamerica.com)  
e-mail: [info@ayase-europe.de](mailto:info@ayase-europe.de)  
e-mail: [info@ayasecorporation.com](mailto:info@ayasecorporation.com)

+1-408-988-5277  
+49-0-6122-533-811  
+81-45-532-9501

